

VMA-Q24x8SE Lab Brick® 24x8 Matrix Attenuator

500 – 6000 MHz Frequency | 90 dB Attenuation Range | 0.1 Step Size | Integrated Server

Features/Benefits

- Reliable and Repeatable solid state digital attenuation
- Includes Windows and Linux SDK
- Single shot or repeating programmable attenuation ramps
- Programmable fading profiles
- Ethernet Control
- Industry leading size - 6 rack units
- Integrated Server

Applications

- WiFi 6, WiFi,
- LTE, 5G, 6G
- MIMO, Multipoint Radio Fading Simulators
- Semiconductor Test and Qualification Labs
- Automated Test Equipment (ATE)



The Vaunix Digital Attenuator Matrix Systems are easily customized, bidirectional, non-blocking test instruments. Attenuation matrixes are ideal instruments for mobile operators, Wi-Fi chip manufacturers and radio development teams testing handover and MIMO performance in research labs, product verification and development environments. The matrix attenuator allows the user to direct multiple input signals to multiple outputs while controlling the signal power on all paths.

The VMA-Q24x8SE Attenuator Matrix System is a rack mounted 24 input x 8 output non-blocking test instrument with an integrated Windows server for independent operation. The VMA-Q24x8SE provides 90 dB of attenuation control range from 500 to 6000 MHz with a step size of 0.1 dB on all 192 possible path combinations. The attenuators are easily programmable for fixed attenuation, swept attenuation ramps and fading profiles using our highly developed Windows API DLL files and Linux platforms.

The VMA-Q24x8SE is AC powered and controlled through a single Ethernet port on the rear of the chassis. RF input signals enter through the rear panel with output signals available on the front panel.

VMA-Q24x8SE Specifications

Parameter	Test Conditions	Min	Typ	Max
Frequency Range (MHz)		500		6000
Impedance (Ω)			50	
Channel Inputs/Outputs		24x8 - Bidirectional		
Attenuation Range (dB)		90		
Step Size (dB)		0.1		
Insertion Loss (dB) (Includes theoretical loss of power dividers)	< 2 GHz		37	
	< 4 GHz		39	
	< 6 GHz		42.5	
Attenuation Accuracy (dB)	<30 dB		1	
	<60 dB		2	
	<90 dB		3	
Switching Speed (μ s)			2	
Maximum Input Level (dBm)			33	
Input IP3 (dBm)		38	45	
VSWR			1.5:1	

Parameter	Test Conditions/Notes	
Power Requirements	110/220 VAC	75 Watts
Environmental	Operating Temperature	0 °C to +40 °C
	Relative Humidity (non-condensing)	<95%
Physical Connections	Power Connector	IEC-60320-C13
	Control	Ethernet
	RF Connectors	SMA – female N - female (Optional)
	Mouse/Keyboard	USB
	Display	HDMI
Operating Modes	Manual Attenuation Control Swept Attenuation – uni/bi directional – one time/repeat Profile	
Mechanical	Size (6RU)	17.0 x 13 x 10.5 inches 431.8 x 330.2 x 266.7 millimeters
	Weight	40 lbs 18.1 kg

VMA-Q24x8SE Functional Diagram

8x8 Matrix

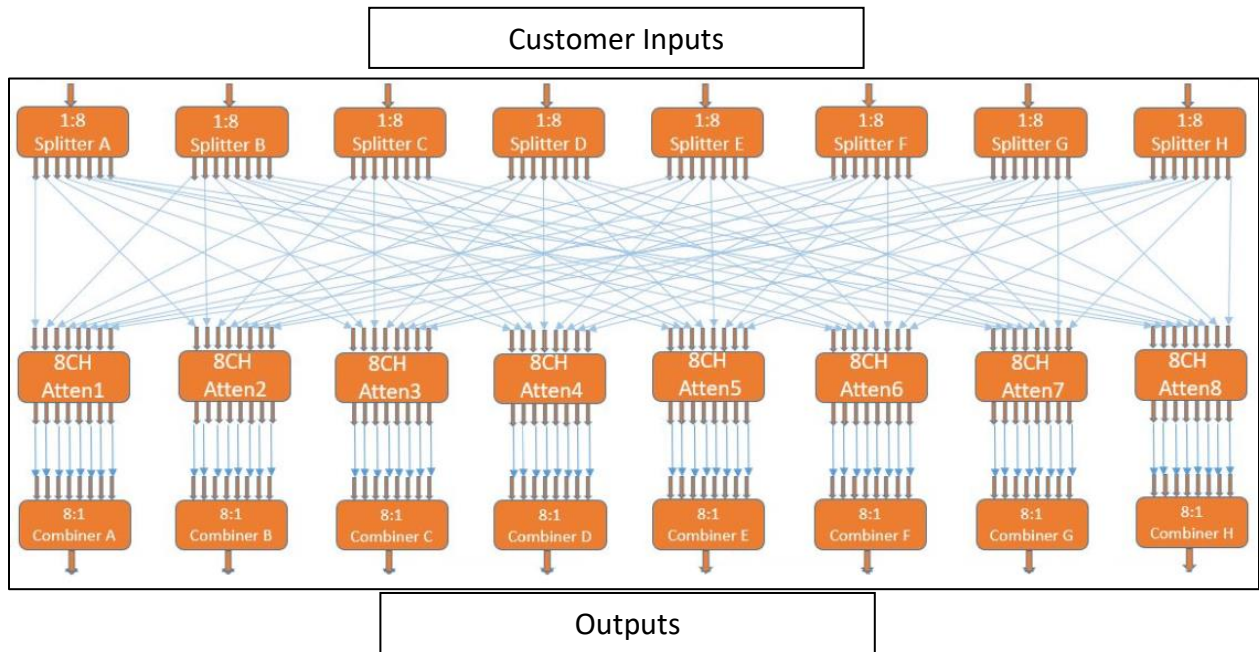

24 x 8 Matrix attenuator

